

# COREX

The water that best suits your home

800 GPD  
REVERSE OSMOSIS

High-end faucet

PRODUCTION  
2,1 L/min



## Healthy hydration

Quality water purified instantly



## Pleasant taste

With a constant and clean flow of water



## Filter change notice

A visual reminder that's convenient and clear



## Extra compact

It fits under the sink without taking up space.



## LED Indicators

Clear and visible information on the status of the equipment

# TECHNOLOGY THAT PROTECTS YOUR EQUIPMENT AND YOUR HOME



## TIMING AQUASTOP

Safety system that stops the equipment after prolonged continuous use, protecting the system and preventing unnecessary consumption.



## EASYPUSH

Quick filter removal designed for safe and efficient technical maintenance.



## DUAL CHOICE

Choose between two types of water: **R.O. water** | **filtered water**



We recommend professional maintenance to ensure maximum equipment efficiency.

## DUAL CHOICE

Choose the water you want

It incorporates two independent water outlets, one for osmosis-treated water and one for filtered water, so you can have the type of water you need at any given time.\*

And if you prefer... **WATER ON DEMAND**

Mix filtered water + reverse osmosis water to get the perfect balance according to your preferences\*\*

What do you gain from all this?

- Hardness and mineral content to suit your personal taste.
- Balanced flavor and purity.
- Optimized sustainability by reducing reverse osmosis consumption when not needed.

\*A 2-way tap is required. Not included. (ref. RO5031)

\*\*An external mixer kit is required. Not included. (ref. CR1071)



## TECHNICAL DATA

- Production: 2.10 L/min
- Membrane: 800 GPD
- Very low rejection: 1:0.5
- Working pressure: 0.4 - 0.9 MPa
- Power: 96W
- High-end faucet.
- Weight: 8.70 kg
- Voltage: AC 220V ~ 50/60Hz
- Inlet water pressure: 0.1 - 0.4 MPa
- Ambient temperature: 2°C - 45°C
- Aquastop timing function
- Filter change indicator
- Dimensions: 127 x 340 x 358 mm

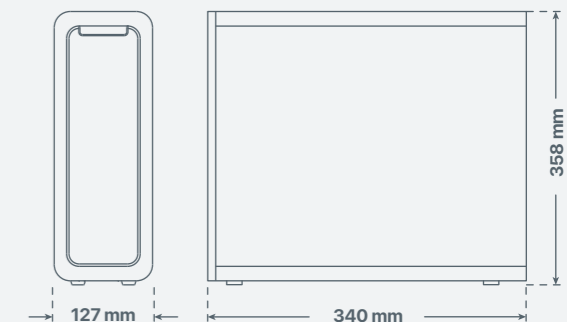



# COREX 800

Advanced technology for  
the well-being of your home

